

FSG-C1224CNC

Turbine Industry Blade
渦輪葉片葉根

Material	工件材質	Inconel(英高鎳)
Hardness	工件硬度	HRC36-40
Machining Size	加工尺寸	20mm(Width of part)
Machining Time	加工時間	4min / 4分 two side Grind amount 7mm

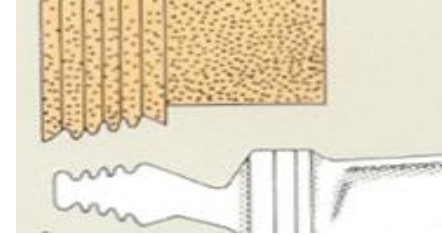

Point of Requirement 需求重點

It takes you only 10 mins to manage to use profile dressing and to form grinding by heavy cutting grinders with high efficiency model of FMG and FSG series.
成型輪廓修整之速成與高效能 FSG and SMART 系列機種

Point of Requirement / 需求重點	Specifications or Accuracy / 規格或精度
Grinding Wheel / 砂輪型式	95A-60-G-13-V (Brand:Elbe Germany)
Demension Accuracy / 尺寸精度	±0.02mm
Surface Roughness / 工件粗度	Ra 0.5 μ m

SMART-B1224III

Turbine Industry Blade 渦輪葉片葉根

Material	工件材質	Inconel(英高鎳)
Hardness	工件硬度	HRC36-40
Machining Size	加工尺寸	20mm(Width of part)
Machining Time	加工時間	8min / 8分 two side Grind amount 7mm

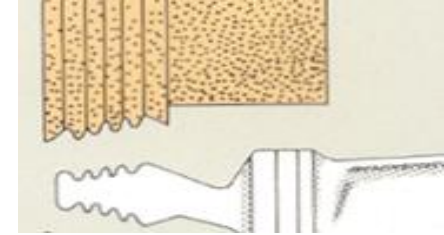

Point of Requirement 需求重點

It takes you only 10 mins to manage to use profile dressing and to form grinding by heavy cutting grinders with high efficiency model of FMG and FSG series.
成型輪廓修整之速成與高效能 FSG and SMART 系列機種

Point of Requirement / 需求重點	Specifications or Accuracy / 規格或精度
Grinding Wheel / 砂輪型式	95A-60-G-13-V (Brand:Elbe Germany)
Demension Accuracy / 尺寸精度	±0.02mm
Surface Roughness / 工件粗度	Ra 0.5 μ m



PRODUCTION CNC GRINDER

FMG-1632CNC-HD

- Table Size (W x L):
400 x 810mm (16" x 32")
- Max. Table Load:
1,500kg (3,326 lbs.)
- Column moving, and capable of Creep Feed function
- Spindle Speed:
1,800rpm (Optional 6,000rpm)
- Table Speed:
X-Axis 10~25,000mm/min (0~88fpm)
Y-Axis 0~3,800mm/min (0~12.5fpm)
Z-Axis 0~4,000mm/min (0~13fpm)
- Spindle motor: up to 75HP

FSG-B818CNC · C1224CNC B2440CNC · B2460CNC · B2480CNC SERIES

- 3-Axis CNC
- FANUC CNC Control
- Table Size (W x L): up to
600 x 2,000mm (24" x 80")
- Column moving
- Capable of creep feed function
- Spindle Speed: up to Capable of
Creep Feed function 5,000rpm, 200
to 5,000rpm some models
- Spindle Power:
15HP (50HP Optional)
Greater Spindle HP Available



**SMART-B818III · B1224III ·
B1640III · B2440III · B2480III ·
B2480III SERIES**

- 3-Axis CNC
- Conversational SMART Control
- Table Size (W x L): up to
600 x 2,000mm (24" x 80")
- Spindle Power: up to 25HP
Greater Spindle HP Available
- Standard Spindle Speed:
1,200rpm to 3,600rpm (higher
spindle rpm is available on request)

09. Turbine Industry Blade/渦輪葉片

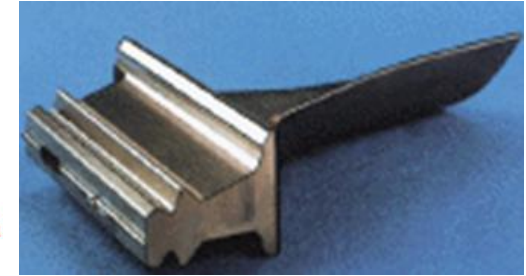
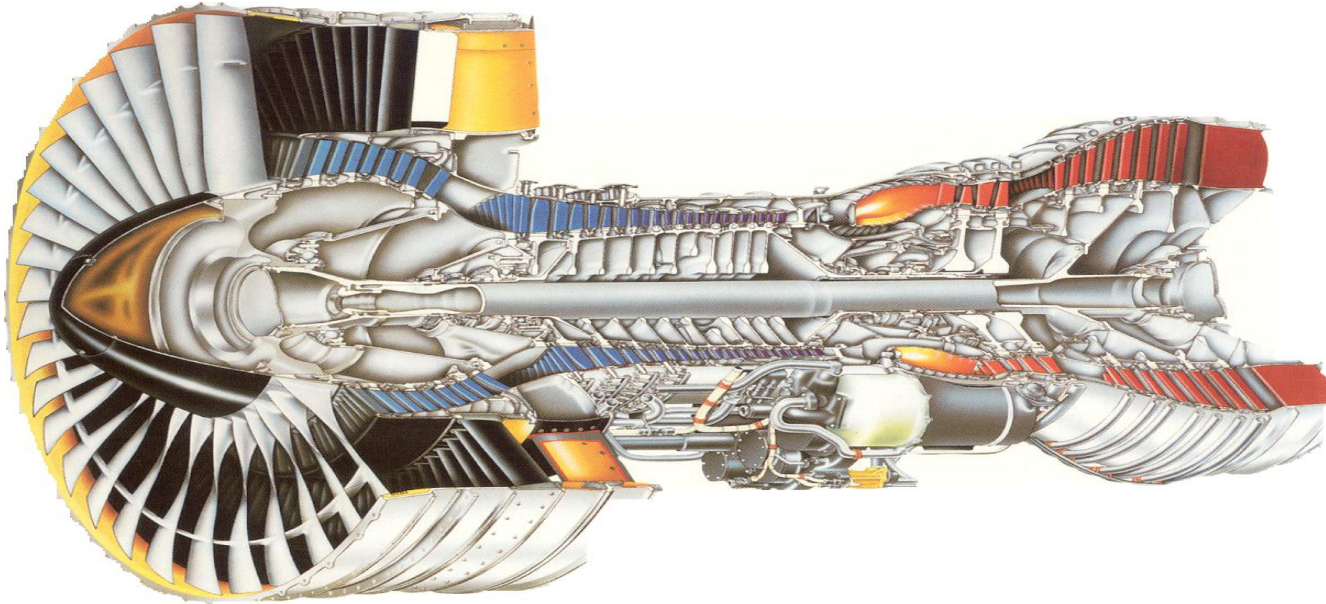

09. Turbine Industry Blade/渦輪葉片

	客戶 Customer	機種 Model	網站 Website
01	America Boeing (美國波音)	SMART-B818III SMART-B1224III FSG-B818CNC FSG-C1224CNC FMG-1632CNC	http://www.boeing.com/boeing/
02	America (GEAE, General Electric Aircraft Engines) 美國通用飛機發動機集團	SMART-B1224III FSG-B818CNC FSG-C1224CNC FMG-1632CNC	The world TOP1 (全世界第一大)
03	UK Rolls-Royce 英國勞斯萊斯	SMART-B1224III FSG-B818CNC	http://www.rolls-royce.com/ The world TOP2 (全世界第二大)
04	Canada (PW, Pratt and Whitney) 加拿大普惠集團	SMART-B1224III FSG-B818CNC FSG-C1224CNC FMG-1632CNC	
05	Pratt & Whitney Repaire Facilities (Singapore service Center) (新加坡維修中心)	FSG-C1224CNC SMART-B1224III	http://www.pw.utc.com/Repair_Facilities
06	Taiwan AIDC Company (台灣漢翔航空)	FSG-C1224CNC	http://www.aidc.com.tw/tw/
07	aiwan Evergreen Aviation technologies corp. (台灣長榮航太)		
08	Avic XI'AN AERO-ENGINE (GROUP) LTD. (中航工業西安航空發動機公司)	SMART-B818III SMART-B1224III FMG-1632CNC	http://www.xaec.com/

09. Turbine Industry Blade/渦輪葉片



09. Turbine Industry Blade/渦輪葉片

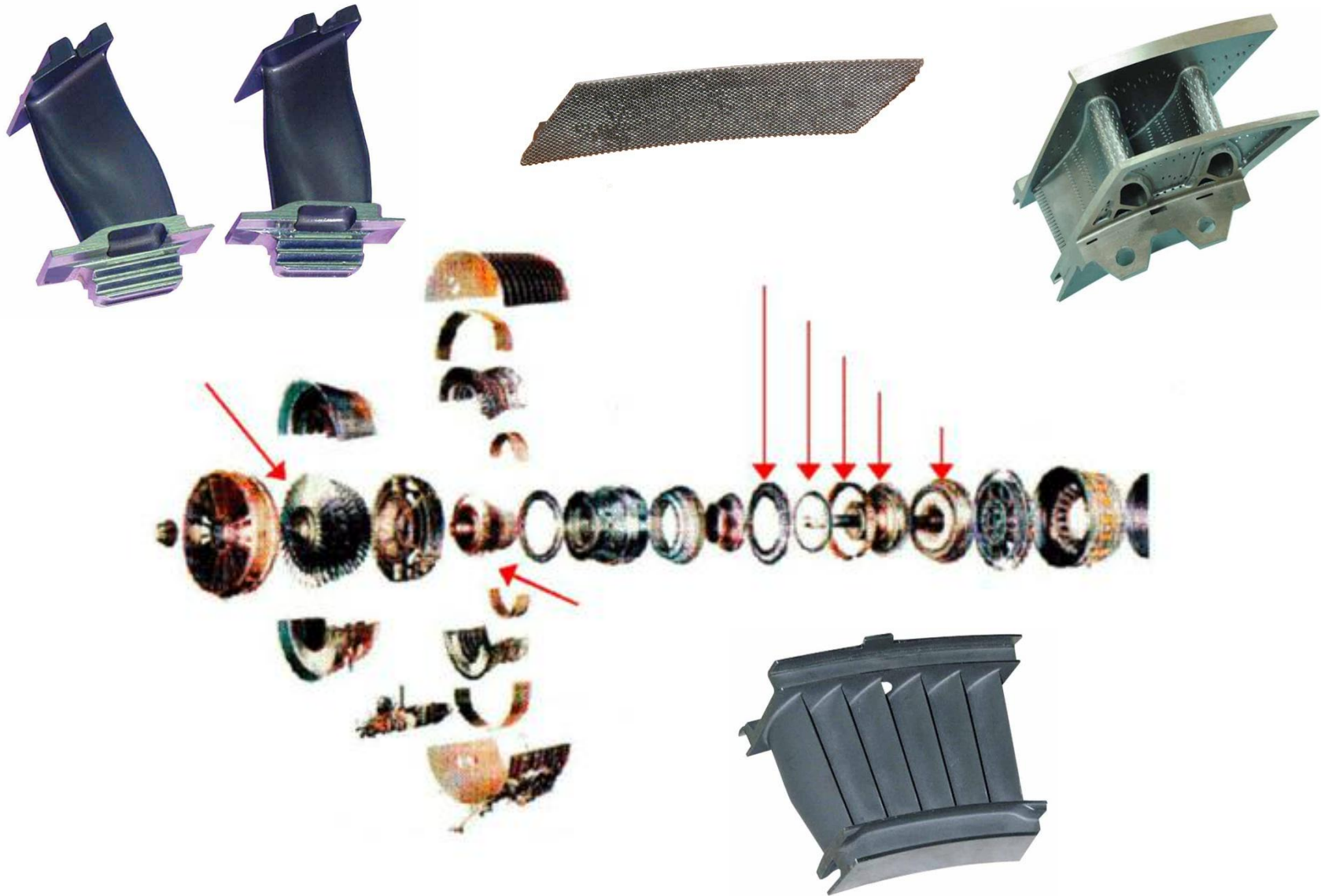

09. Turbine Industry Blade/渦輪葉片

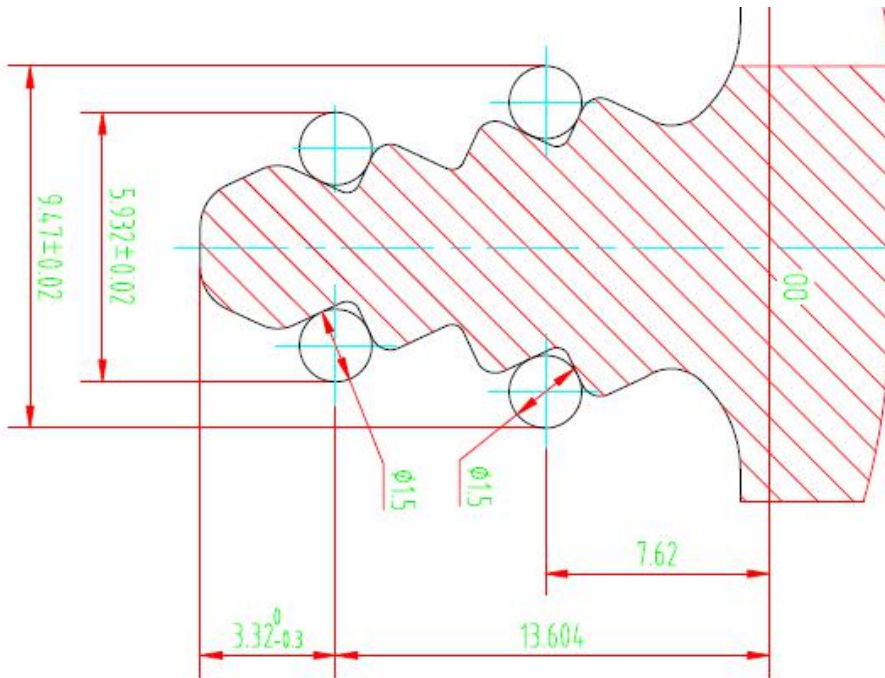

09. Turbine Industry Blade/渦輪葉片

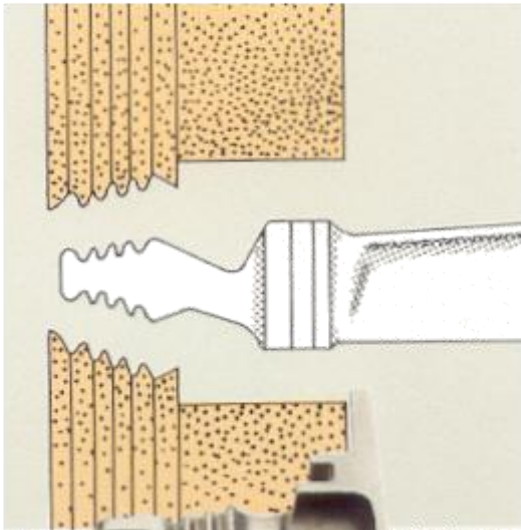

Material(材質)

- ❑ Inconel (英高鎳)
- ❑ Titanium Alloy(鈦合金)
- ❑ Stainless Steel (不鏽鋼)



09. Turbine Industry Blade/渦輪葉片

葉片灌合金
Forming

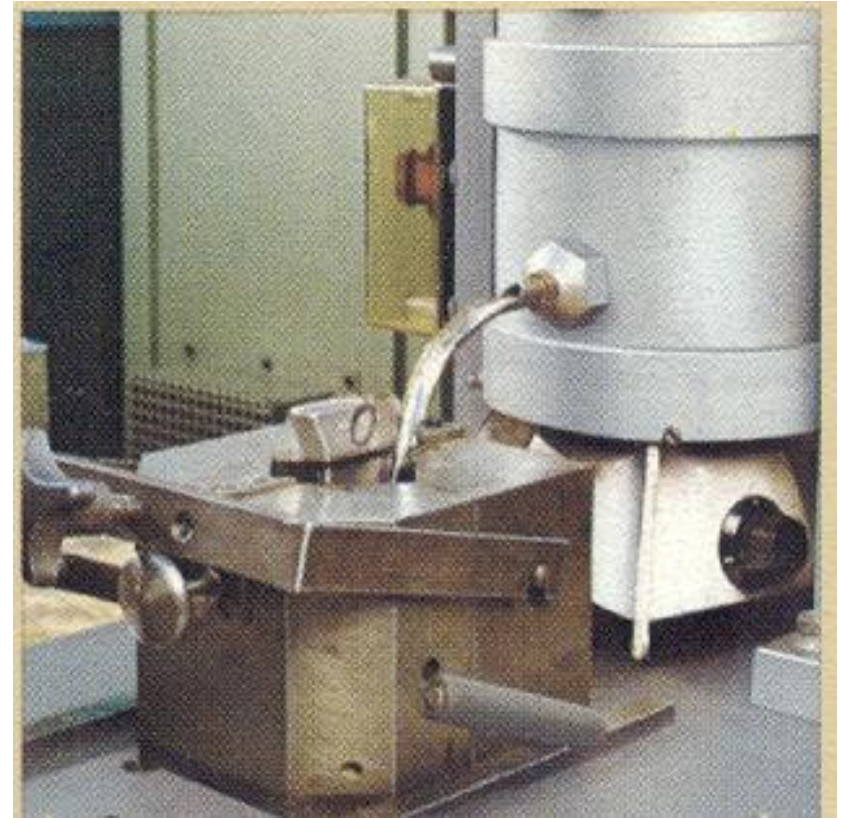

09. Turbine Industry Blade/渦輪葉片

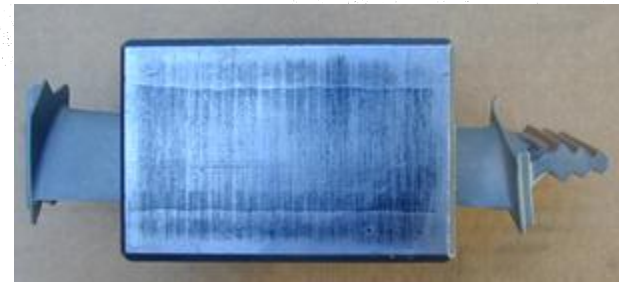
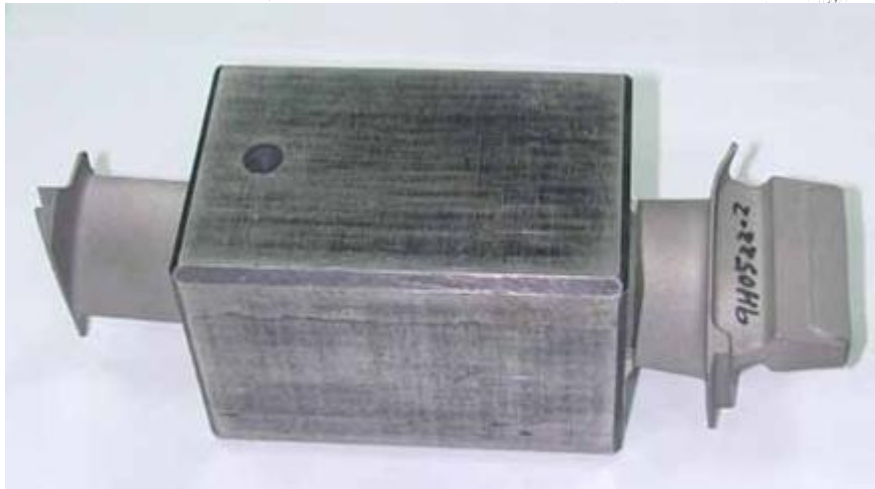
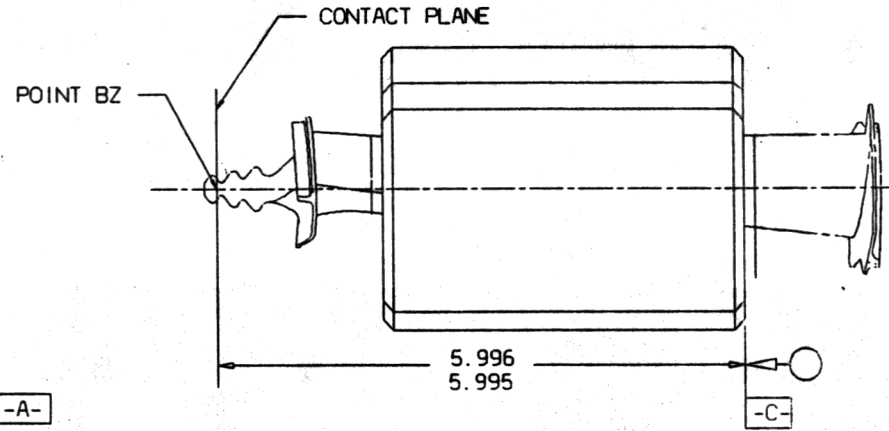
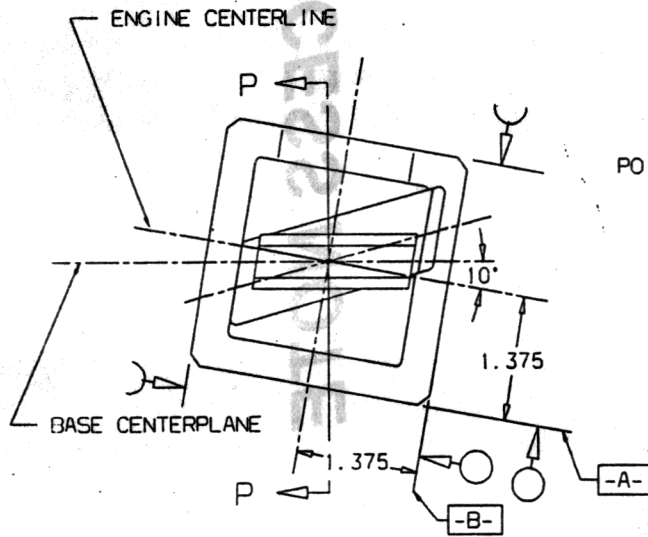

葉片固定塊(Blade fix block)

09. Turbine Industry Blade/渦輪葉片

Dresser
On the top
輪頭修整器

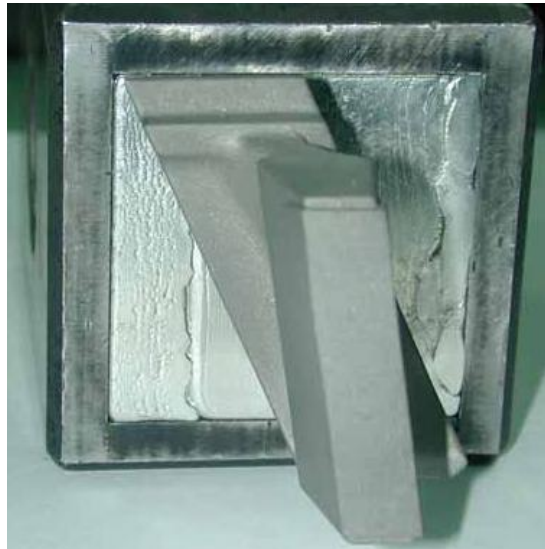

09. Turbine Industry Blade/渦輪葉片

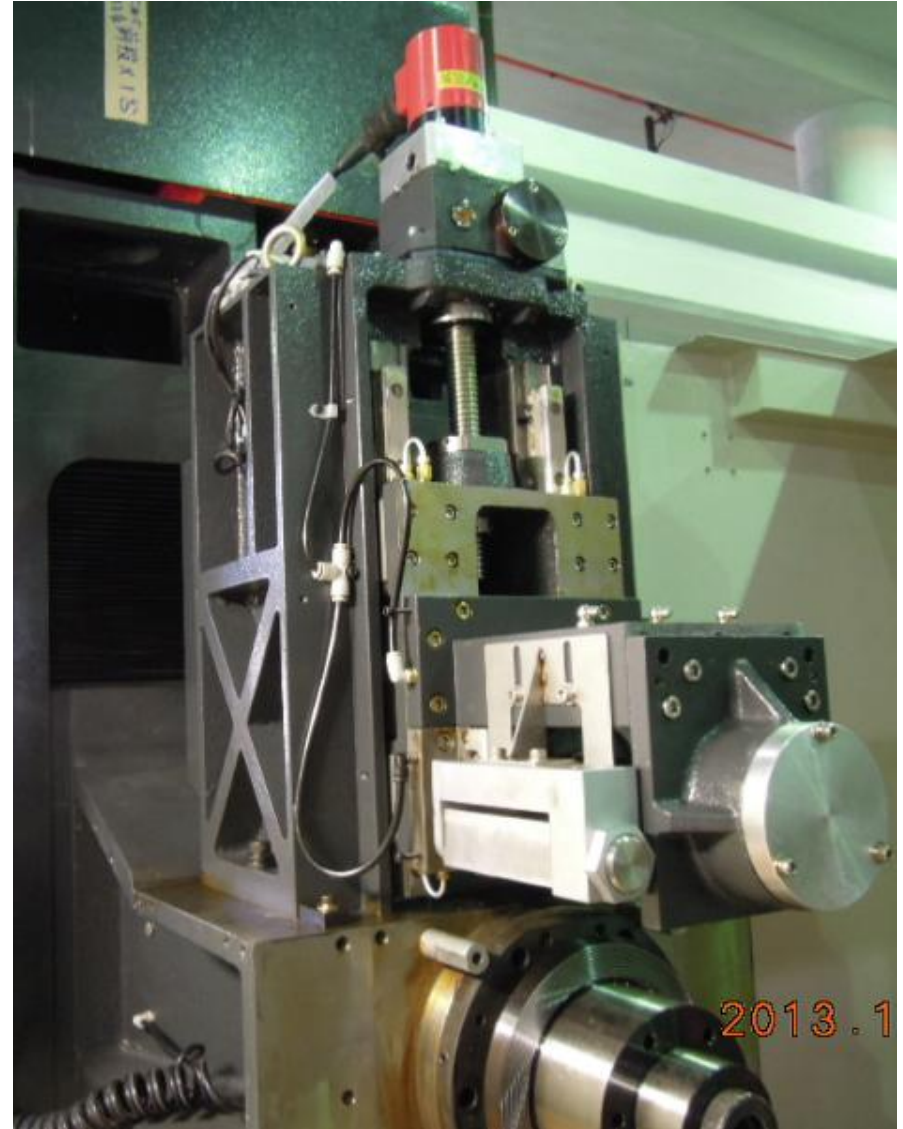
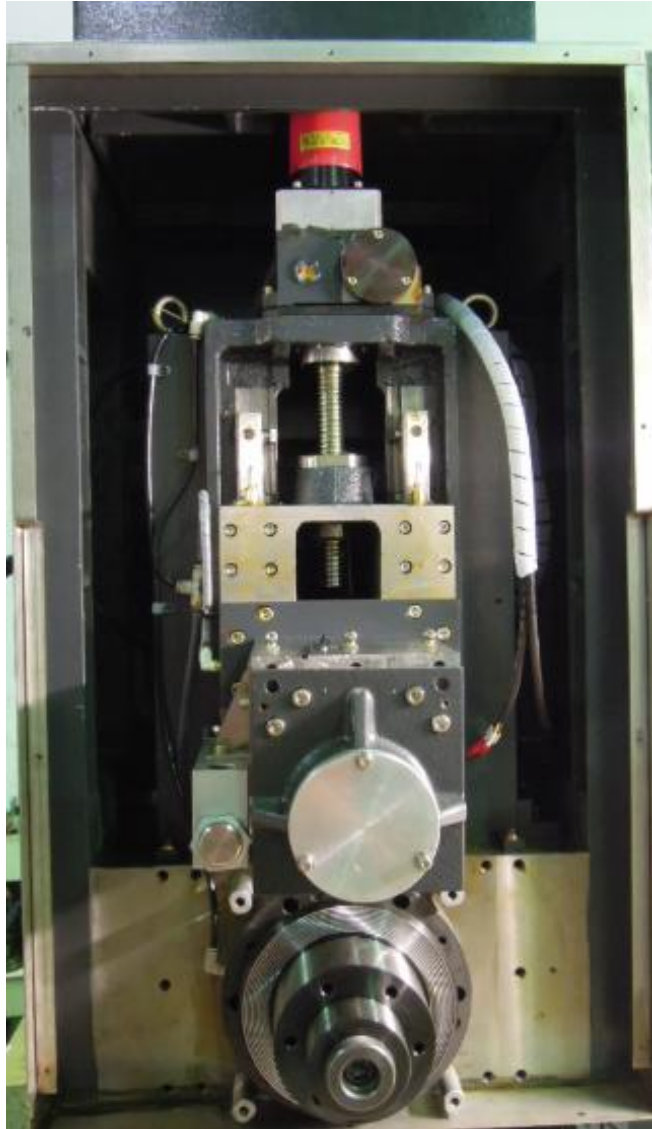

09. Turbine Industry Blade/渦輪葉片

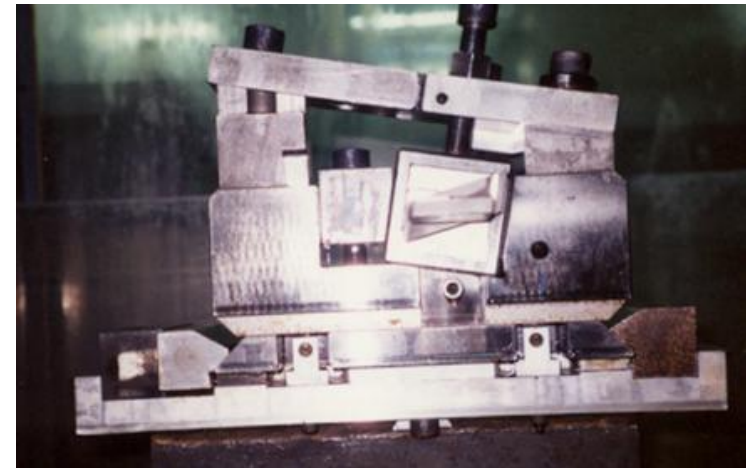
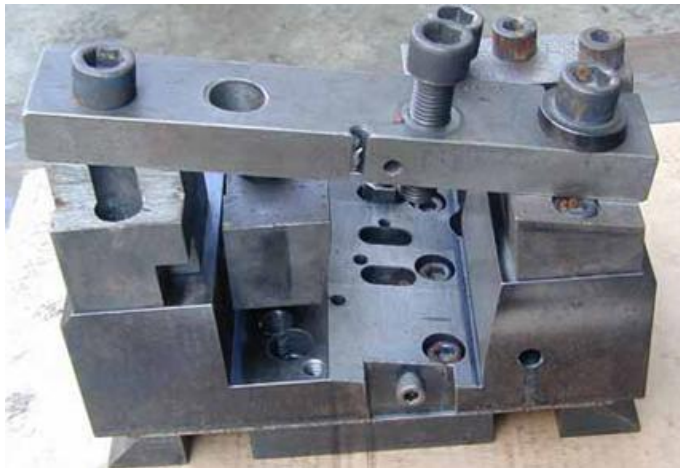
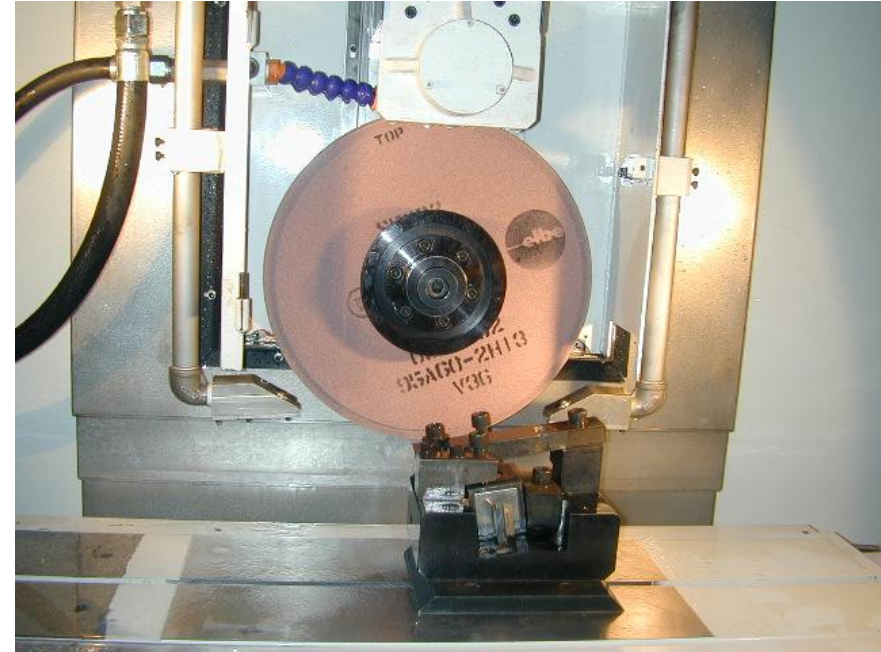

09. Turbine Industry Blade/渦輪葉片



09. Turbine Industry Blade/渦輪葉片

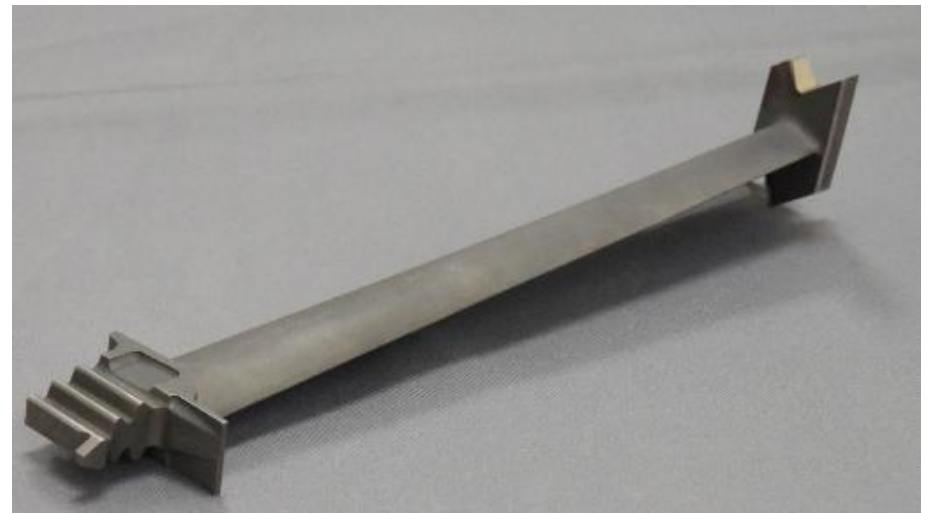

09. Turbine Industry Blade/渦輪葉片



09. Turbine Industry Blade/渦輪葉片

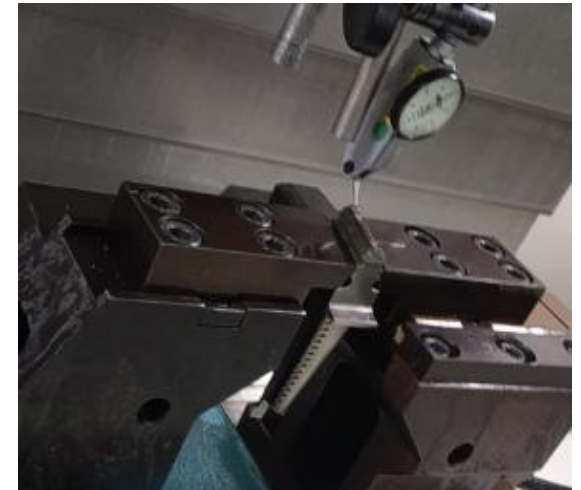

09. Turbine Industry Blade/渦輪葉片

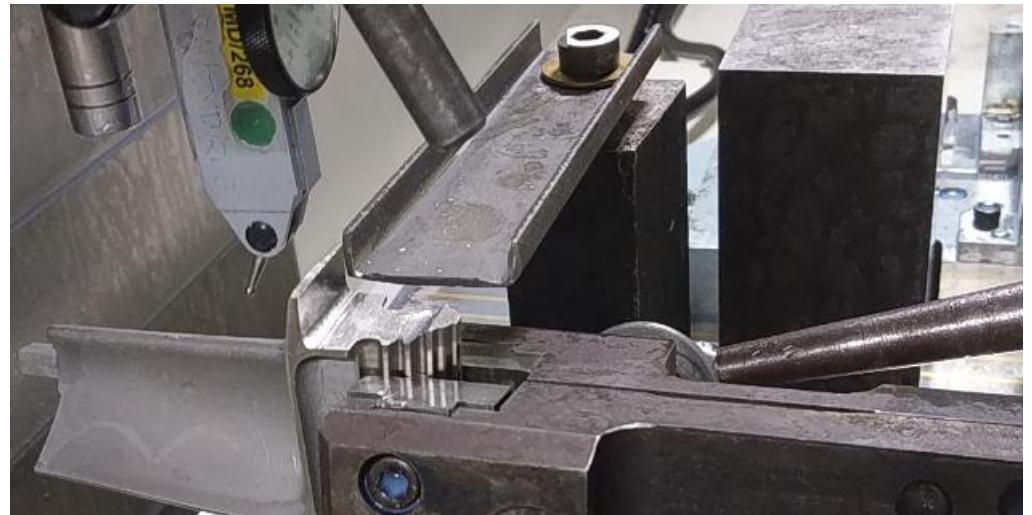
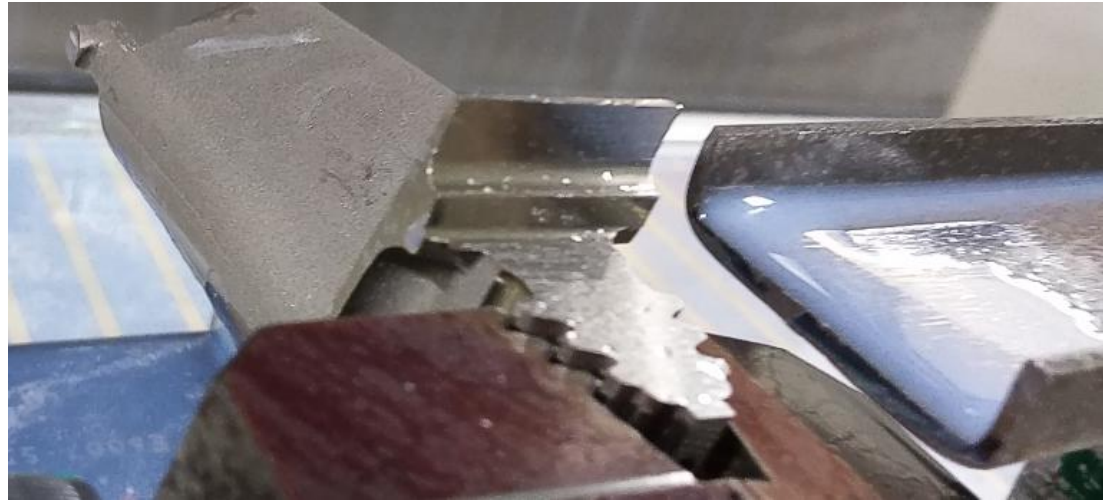
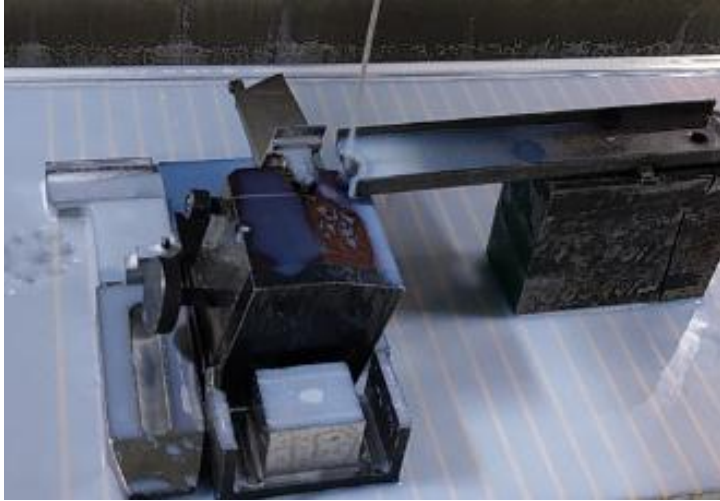

09. Turbine Industry Blade/渦輪葉片

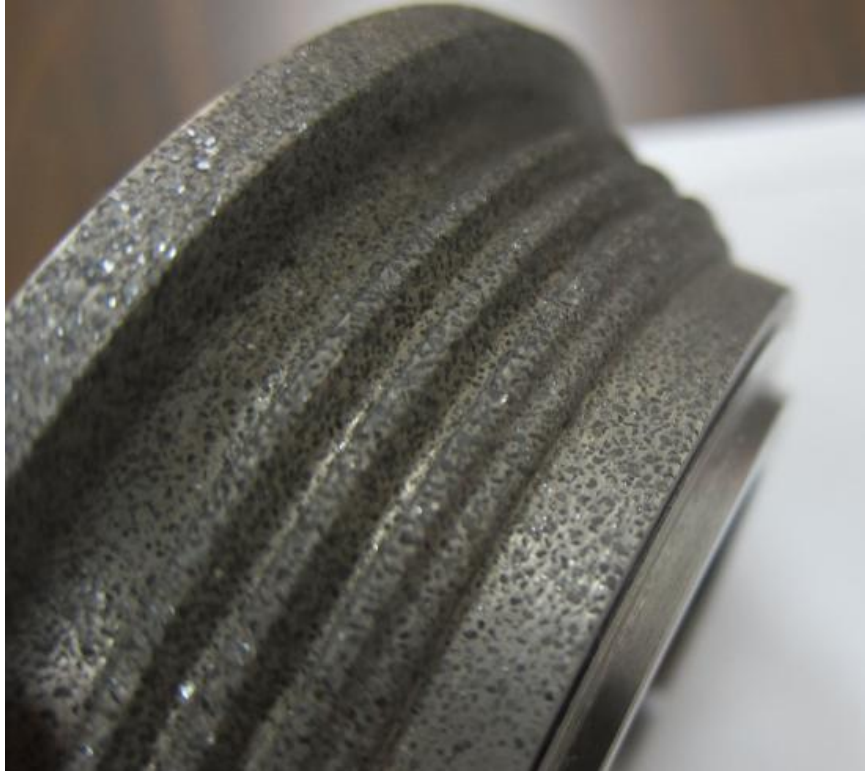

09. Turbine Industry Blade/渦輪葉片



09. Turbine Industry Blade/渦輪葉片



09. Turbine Industry Blade/渦輪葉片

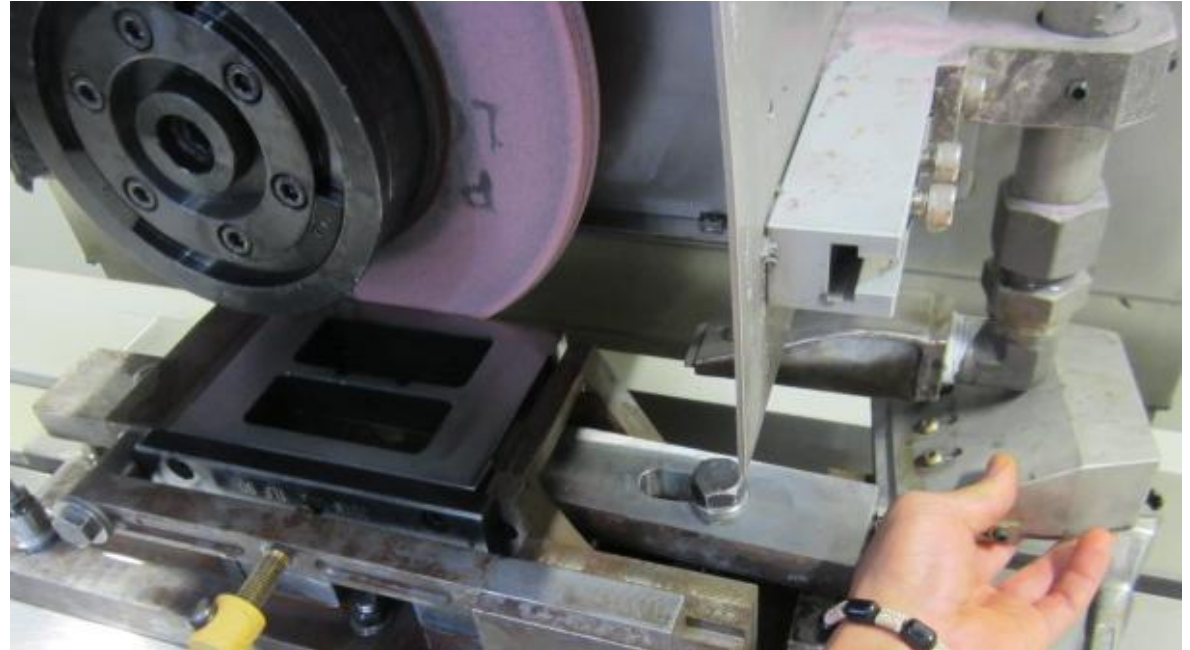
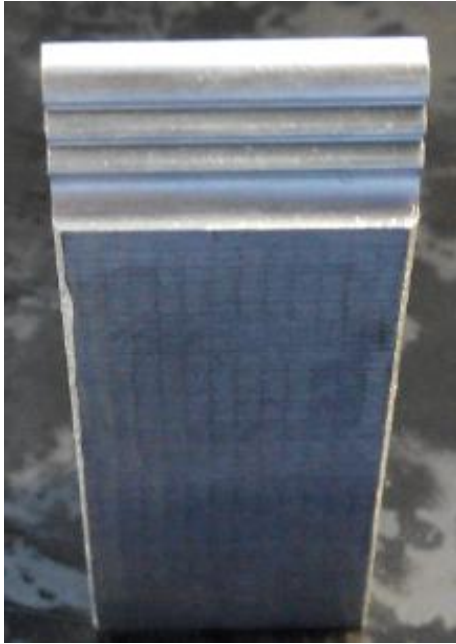

09. Turbine Industry Blade/渦輪葉片



09. Turbine Industry Blade/渦輪葉片



09. Turbine Industry Blade/渦輪葉片

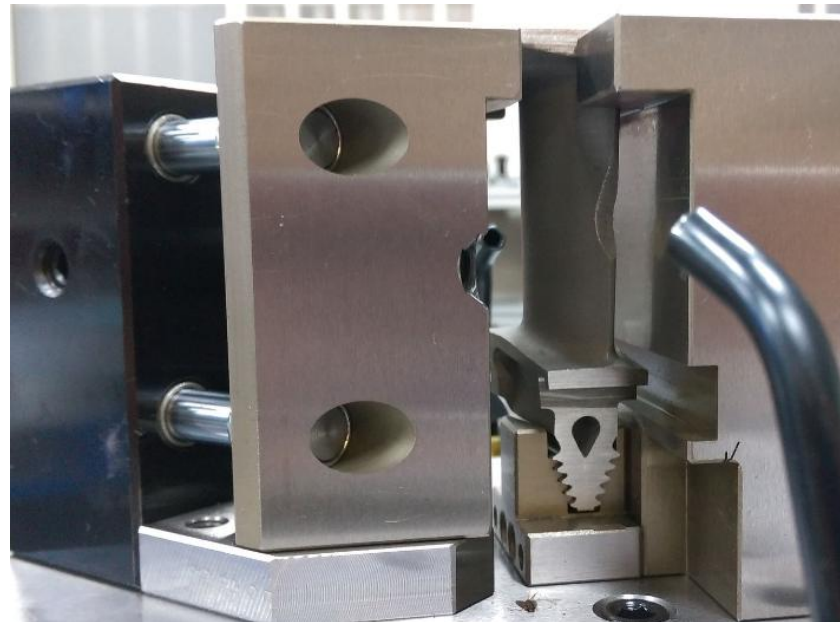
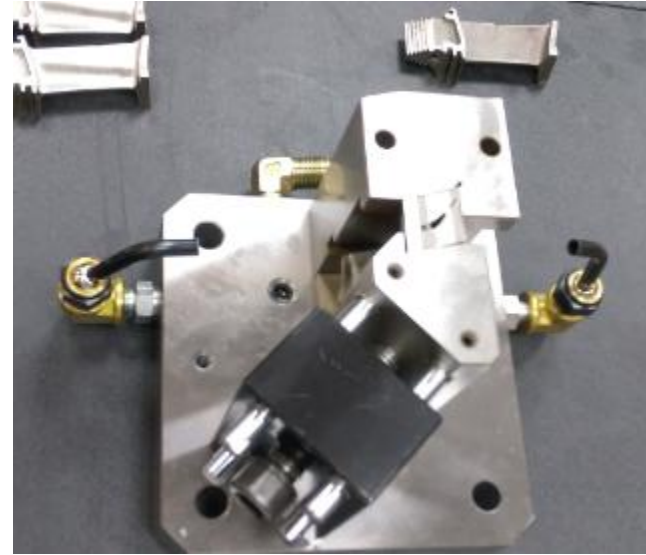

09. Turbine Industry Blade/渦輪葉片



09. Turbine Industry Blade/渦輪葉片

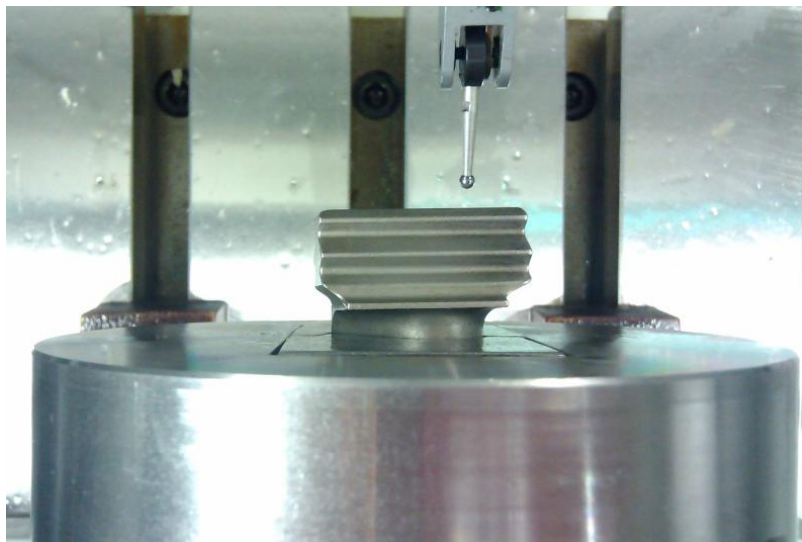

09. Turbine Industry Blade/渦輪葉片

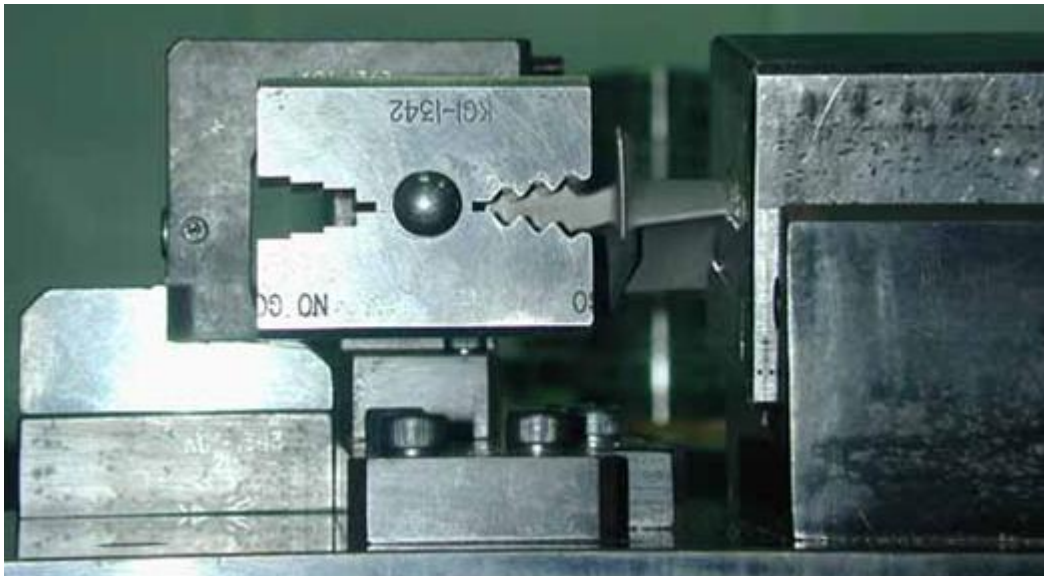
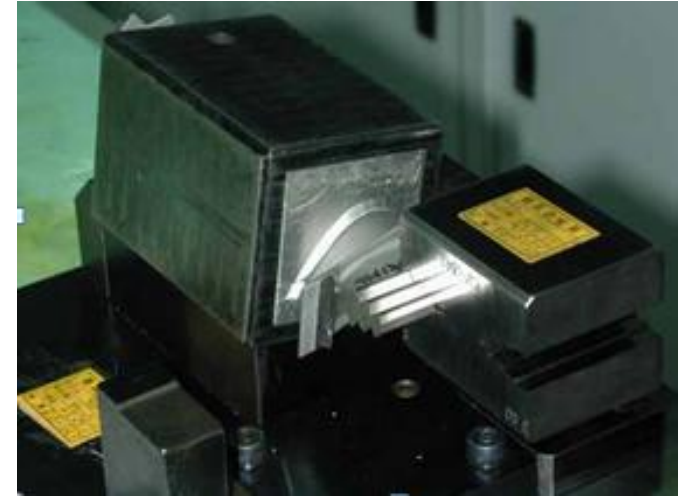

09. Turbine Industry Blade/渦輪葉片



09. Turbine Industry Blade/渦輪葉片

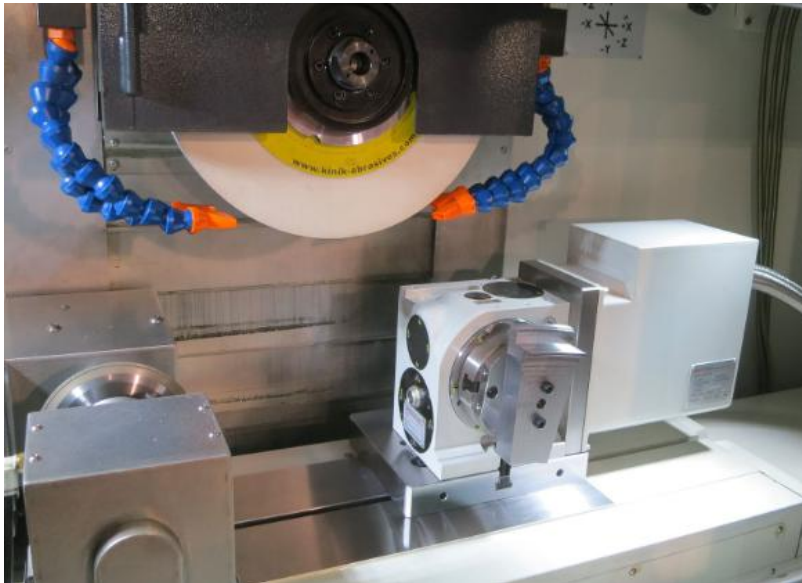

09. Turbine Industry Blade/渦輪葉片



09. Turbine Industry Blade/渦輪葉片



09. Turbine Industry Blade/渦輪葉片

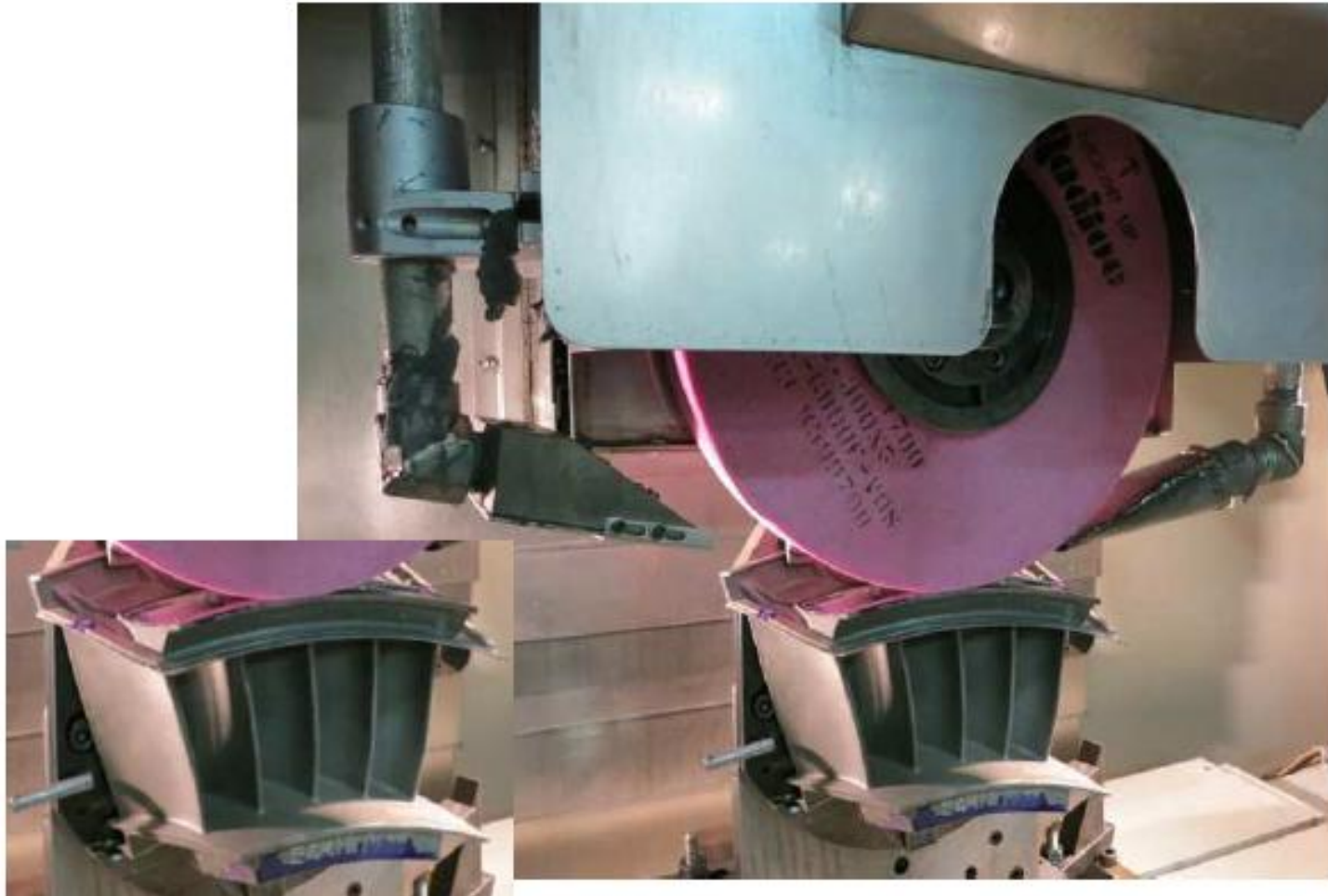

09. Turbine Industry Blade/渦輪葉片

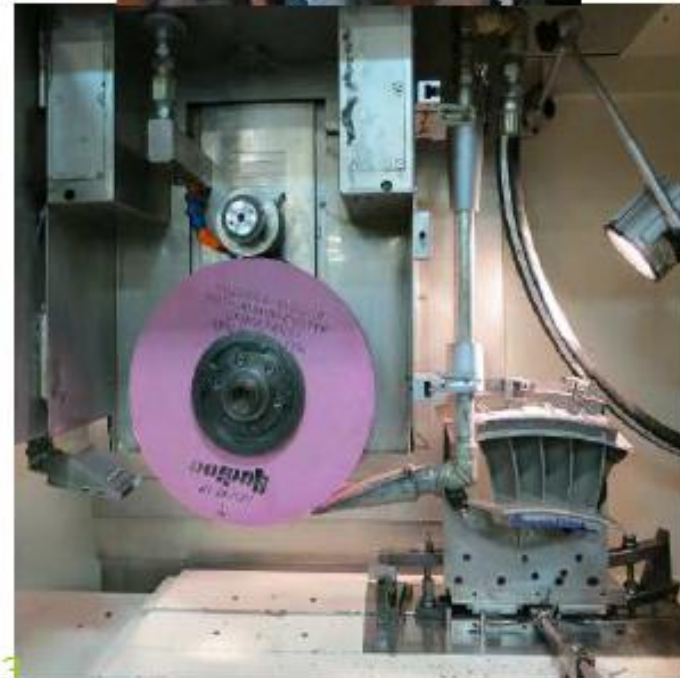

09. Turbine Industry Blade/渦輪葉片



09. Turbine Industry Blade/渦輪葉片



09. Turbine Industry Blade/渦輪葉片



09. Turbine Industry Blade/渦輪葉片

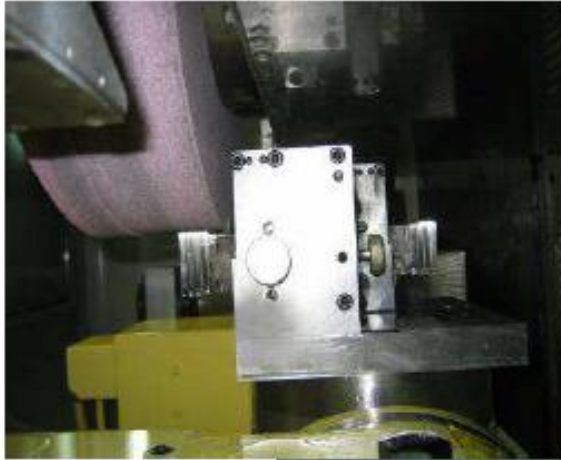

09. Turbine Industry Blade/渦輪葉片



09. Turbine Industry Blade/渦輪葉片

Turbine Honeycomb Seals (蜂巢散熱片)

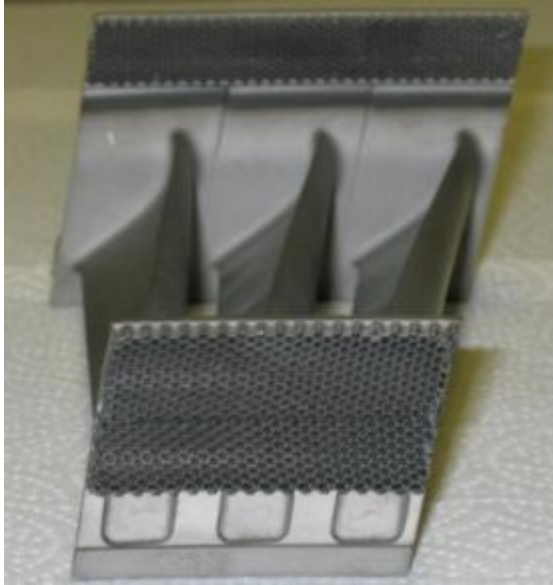

09. Turbine Industry Blade/渦輪葉片

Turbine Honeycomb Seals (蜂巢散熱片)

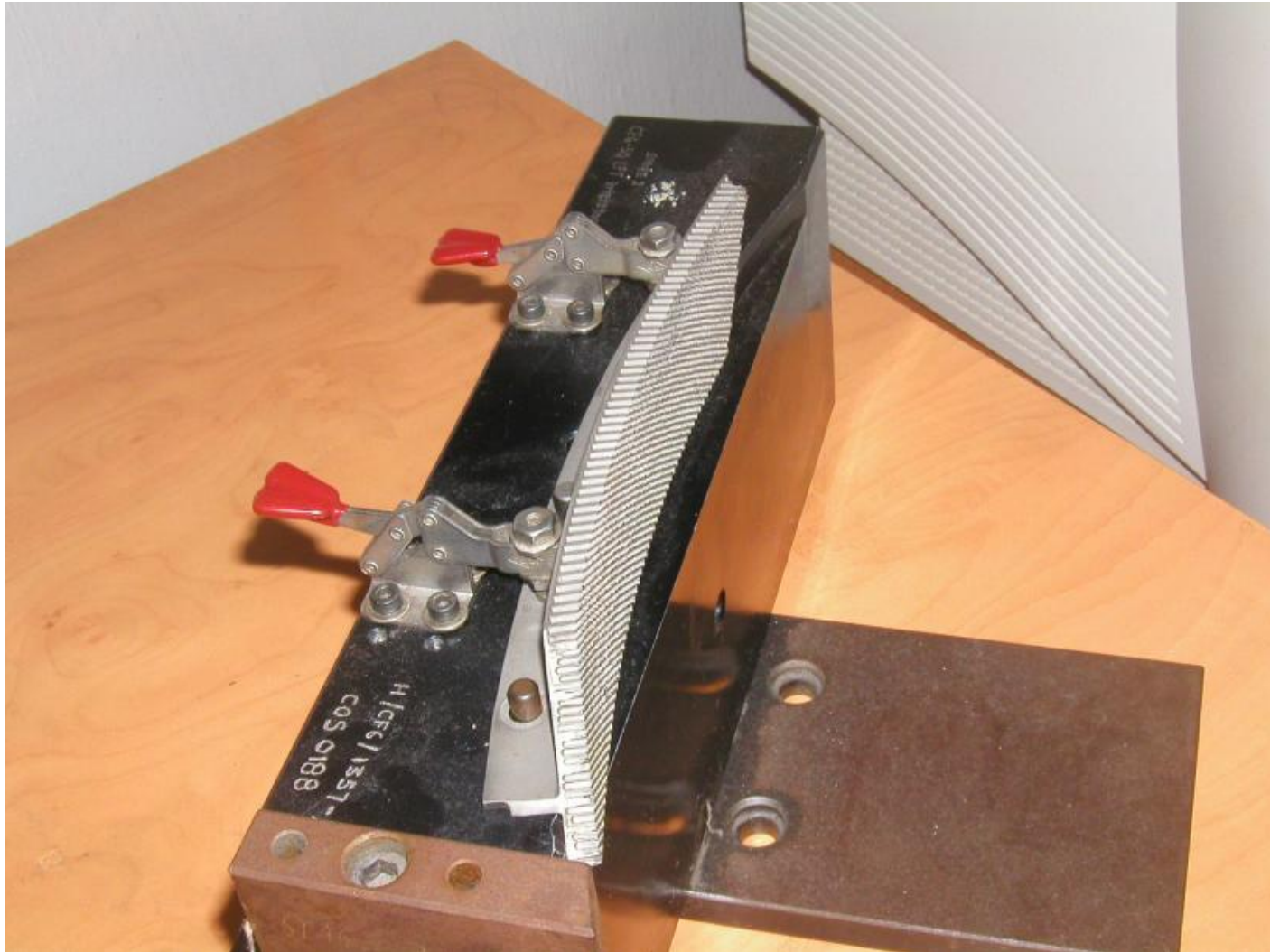

09. Turbine Industry Blade/渦輪葉片

Turbine Honeycomb Seals (蜂巢散熱片)

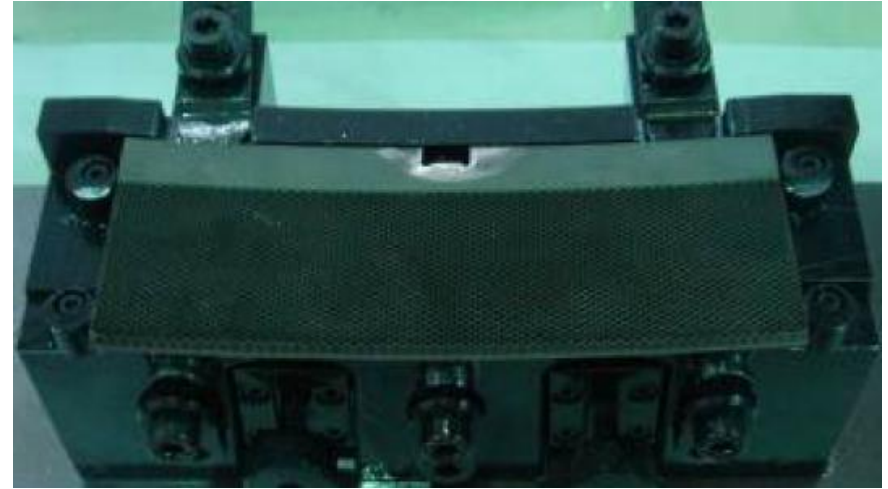

09. Turbine Industry Blade/渦輪葉片

Turbine Honeycomb Seals (蜂巢散熱片)

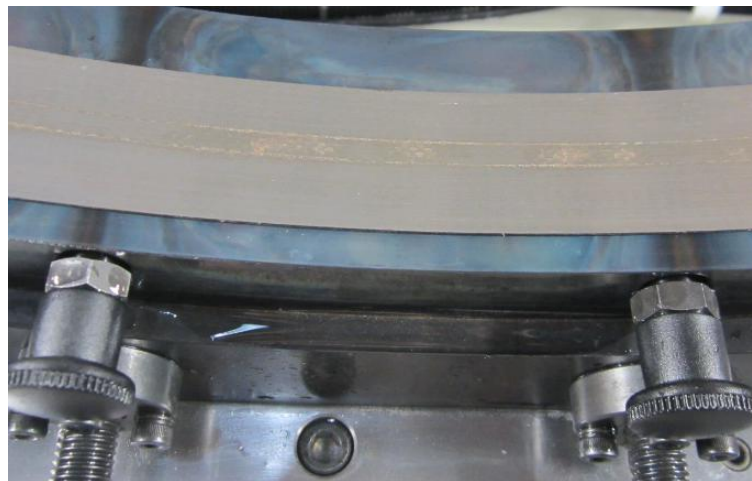
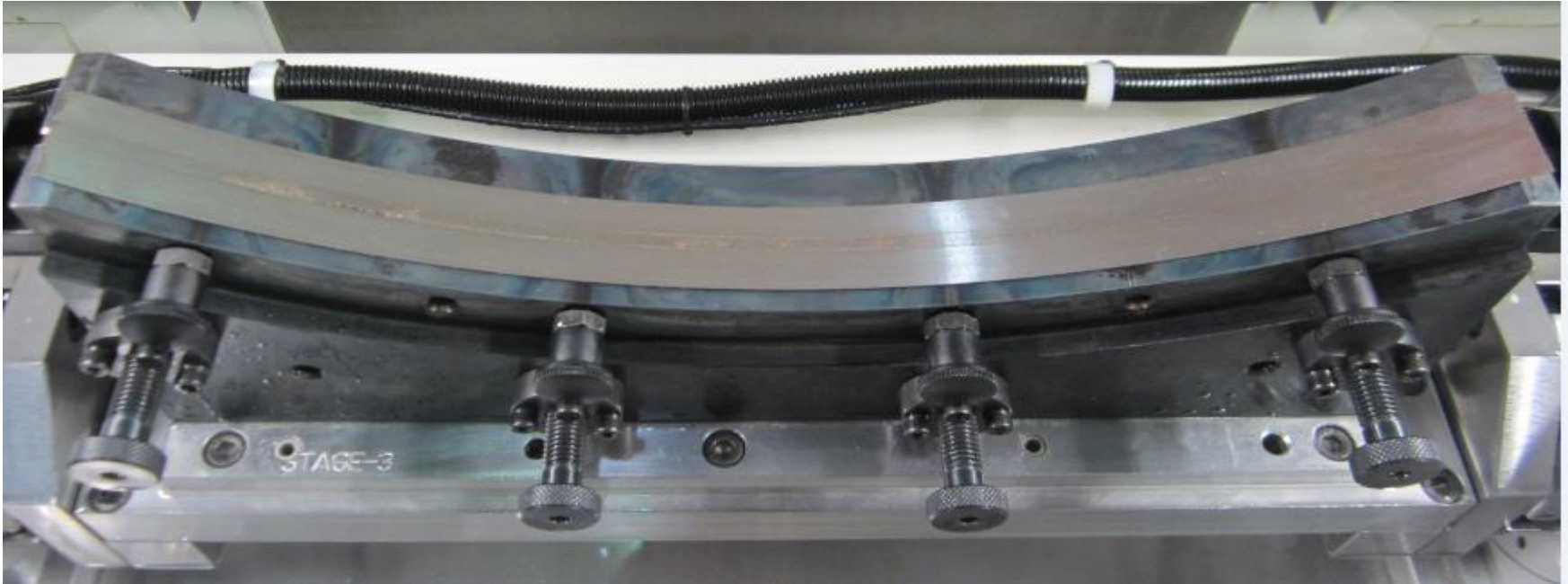

09. Turbine Industry Blade/渦輪葉片

Turbine Honeycomb Seals (蜂巢散熱片)

G54	O995511 N0 L1	圖形對話程式選單	2014/01/07	17:17:39
PU ▲	參數 1	參數 2	參數 3	參數 4 ▼ PD

相對座標	
X	-198.300
Y	90.701
Z	47.295

工件編號	IN-ST-3 ▼
選擇執行動作	研磨搭修整 ▼
額外研磨量	0.000
研磨對刀點	X軸
	-634.860
	Y軸
	-142.157
	Z軸
	-203.000
	A軸
	0

研磨對刀點

X: 中心對中心

Y: 碰觸對刀

Z: 目視對刀

砂輪外徑

350.240

研磨砂輪線速度

1600

工件圖紙尺寸設定

角度 A

72

加工目標 R

335.840

		(-640~630)	●就緒	手輪	警報		
<<	F1 座標切換	F2 清除相對座標	F3 狀態監測	F4 寫入機械座標	F7 退出對話	F8 檔案管理	>>

09. Turbine Industry Blade/渦輪葉片

Turbine Honeycomb Seals (蜂巢散熱片)

G54 O995511 N0 L1 圖形對話程式選單 2014/01/07 17:17:42

PU ▲ 參數 1 參數 2 參數 3 參數 4 ▼ PD

相對座標

研磨總量 T	X -198.300	目前已研磨量
5.100	Y 90.701	5.100
	Z 47.295	

粗磨總量 5.000 細磨總量 0.100

粗磨單次進刀量 0.100 細磨單次進刀量 0.020

粗磨進給速度 2000 細磨進給速度 3000

粗磨修整間隔量 1.200 零研磨次數 1

接近工件高度 0.100 幾個工件後修砂輪 0

G54 O995511 N0 L1 圖形對話程式選單 2014/01/07 17:17:45

PU ▲ 參數 1 參數 2 參數 3 參數 4 ▼ PD

相對座標

砂輪修整模式	X -198.300	目前已修整量	修整砂輪線速度
直線修整 ▼	Y 90.701	0.000	1000
	Z 47.295		修整總量

修整行程 50.000

修整單次進刀量 0.100

修整進給速度 300

修整起始點

X軸	0.000
Y軸	-222.329
Z軸	-186.984

09. Turbine Industry Blade/渦輪葉片



09. Turbine Industry Blade/渦輪葉片

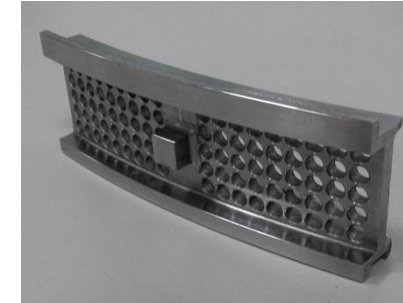

09. Turbine Industry Blade/渦輪葉片

G54 | O970007 N0 L1 | 溝槽研磨 | 2014/05/14 | 10:57:52
 PU ▲ 參數 1 | 參數 2 | 參數 3/3 | Option ▼ PD

機械座標
 X -298.116
 Y -26.124
 Z -106.095
 A 0.000

工件編號: DASH8
 砂輪名稱: T6*

溝槽種類: 等深等距

啓始機械座標: -355.000, -120.000, -30.000

A軸: 0.000

砂輪表面速度: 2000, 50.000

溝槽個數: 0, 0.000

G54 | O970007 N0 L1 | 溝槽研磨 | 2014/05/14 | 10:57:55
 PU ▲ 參數 1 | 參數 2 | 參數 3/3 | Option ▼ PD

機械座標
 X -298.116
 Y -26.124
 Z -106.095
 A 0.000

總研磨量: 7.000
 粗研磨: 7.000, 0.070
 選擇下刀邊: 雙邊進刀
 過面次數: 0

10000.000
 使用分度頭: Y進刀
 分度頭旋轉次數: 7

X軸進給速率

細研磨: 0.000, 0.000
 選擇下刀邊: 雙邊進刀
 過面次數: 0

0.000
 零研磨次數: 0

額外研磨量: 0.000

X軸進給速率

09. Turbine Industry Blade/渦輪葉片

G54 O970007 N0 L1 溝槽研磨 2014/05/14 10:59:40
 參數 1 參數 2 參數 3/3 Option PD

機械座標
 X -298.116
 Y -26.124
 Z -106.095
 A 0.000

工件編號: DASH8 F
 砂輪名稱: T6*

溝槽種類: 等深等距
 啓始機械座標: -355.000
 -127.000
 -30.000

A軸: 0.000

砂輪表面速度: 2000
 50.000
 0.000

溝槽個數: 0
 0.000

G54 O970007 N0 L1 溝槽研磨 2014/05/14 11:03:04
 參數 1 參數 2 參數 3/3 Option PD

機械座標
 X -298.116
 Y -26.124
 Z -106.095
 A 0.000

總研磨量: 0.050
 粗研磨: 0.050
 0.025

選擇下刀邊: 雙邊進刀
 過面次數: 0

5000.000
 使用分度頭 Y進刀
 分度頭旋轉次數: 2

X軸進給速率

細研磨: 0.000
 0.000

選擇下刀邊: 雙邊進刀
 過面次數: 0

5000.000
 零研磨次數: 2
 額外研磨量: 0.000

X軸進給速率

09. Turbine Industry Blade/渦輪葉片

G54 | O970014 N0 L1 | 輪廓修整 | 2014/05/14 | 10:58:12

砂輪編號: DASH8
砂輪名稱: T6*
修整器位置: 前端
新舊砂輪: 舊砂輪

機械座標
X: -298.116
Y: -26.124
Z: -106.095
A: 0.000

355.000
砂輪表面速度: 1000
0.050
0.025
進給速率: 150.000
修整器位置: 0.000, -26.124, -106.095
0.250

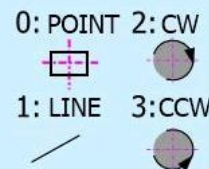

工作平面
Z-Y(NC-X)
座標種類
相對式
頁數
1 / 2

Line	Type	Y	Z	F	DWELL
1	1	-3.000	-3.000		
2	2	-0.146	-0.354	0.500	
3	1	0.000	-2.000		
4	3	-0.289	-0.345	0.350	
5	1	-0.902	-0.159		
6	2	-1.232	-1.476	1.500	
7	1	0.000	-0.489		
8	3	-0.156	-0.377	0.533	
9	1	-1.205	-1.205		
10	2	0.000	-1.257	0.890	

